

SPECIAL EDITION

E75 Food Waste Disposer



The premium range of food waste disposers



The E75 food waste disposer features a new style black and silver trim shell with a premium stainless steel sink stopper. It has a compact, space saving design. Supplied with built-in air switches in matte black, chrome and brushed steel it is supported by a 6 year parts and service guarantee.



FEATURES

- Built-in air switch in matte black, chrome and brushed steel
- 6 Year guarantee
- New style trim shell
- Removable sound baffle
- Stainless steel grind elements
- Continuous feed
- Powerful induction motor
- Overload protection
- Quick Lock® mounting assembly for faster, easier installation
- Cast lugs

**PRODUCT
SPEC SHEET**

**E75
Food Waste Disposer**

**S H O W R O O M
C O L L E C T I O N**

DIMENSIONS (mm)

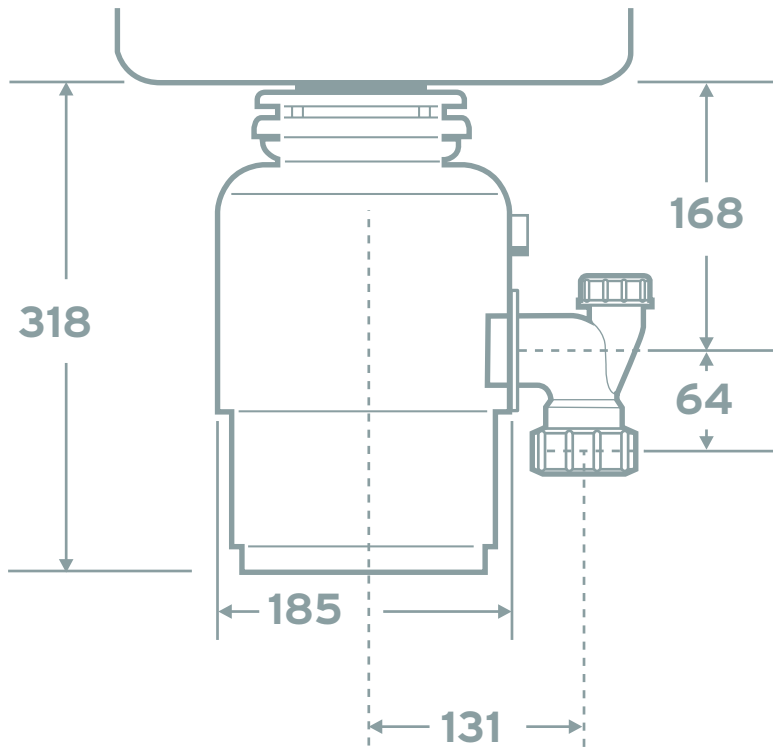

SPECIFICATIONS

Type of feed	Continuous
On/Off Control	Wall switch or built-in air switch
Motor	Single phase
Reversing	None
Time Rating	Intermittent
Lubrication	Permanently lubricated upper & lower bearings
Shipping Weight (Approx.)	8.2kg
Unit Finish	Black
Overall Height	318mm
Grind Technology	1-stage grind technology
Sound Technology	None
Grind Chamber Capacity	980ml
Motor Protection	Manual reset overload
Average Water Usage	Approximately 4.0L per person per day
Average Electrical Usage	3-4KWH per annum
Drain Connection	Yes
Dishwasher Drain Connection	Yes



The Air Switch button is available in three colour choices.

Premium stainless steel stopper with cover.

Volts/Hz	HP	Average load
220-240V, 50-60Hz	.75 (@240V/50Hz)	405 W



InSinkErator. Suite 10, Building 6, Hatters Lane, Croxley Park, Watford, Herts WD18 8YH. United Kingdom

Sales tel: 01923 297 880
Service tel: 0800 389 3715
insinkerator.co.uk

